

STRONG BUILT FLOORS

Installation & Maintenance Instructions



INSTALLATION TOOLS REQUIRED

- Spacers/Shims
 - Utility Knife
 - String Line
 - Rubber Mallet
 - Tape Measure
 - Square
 - Hand Saw, Circular Saw, Jig Saw
 - Pencil
 - Pull/Pry Bar
-

PRE-INSTALLATION CHECKLIST

NORMAL ROOM CONDITIONS (NRC): Normal room conditions are defined as; ambient air temperature between 60-85 degrees Fahrenheit; surface temperature between 60-85 degrees Fahrenheit; ambient RH (Relative Humidity) between 35%-55%. Flooring should be the last material installed on a project. Make sure all painting and drywall is done, doors and windows are installed, and HVAC system is installed and operating.

ACCLIMATION: Flooring products are designed to perform in normal room conditions (NRC) ambient temperature and surface temperature must be between 60-85 degrees Fahrenheit, ambient relative humidity (RH) must be between 35-55%. Flooring products must achieve and maintain NRC prior to, during, and after installation. Temperature readings must be taken and documented, including ambient room temperature and surface temperature. Acclimate cartons laying flat, not on end or on side, stacked no more than 5 cartons high. Avoid storing flooring direct sunlight. Do not store on radiant in-floor heated areas.

SUBFLOOR MOISTURE CONCRETE SUBSTRATES: Moisture levels in concrete substrates must be no higher than 80% Relative Humidity (ASTM F2170) and MVER of ≤ 3 lbs./1000 sf in 24 hours (Calcium Chloride Test ASTM F1869). For levels higher than approved levels, additional dry time and/or moisture mitigate with a product designed to reduce moisture level to acceptable level are required. Subfloor pH must be between 5-9 on a pH scale. It is difficult to measure gypsum substrates for moisture. Although Relative Humidity Probes (ASTM F2170) are the recommended method of testing, they are not practical due to the number of tests required and often the thickness of the gypsum. A professional electronic moisture indicator (Protimeter Aquant recommended) can be used to indicate if the substrate is dry enough to receive floor covering. **Note: Concrete substrates must be properly cured and meet moisture requirements. All concrete substrates on or below grade are required to have an approved poly film moisture barrier with minimum 6mil thickness properly installed.*

SUBFLOOR MOISTURE WOOD SUBSTRATES: Moisture levels in wood underlayment should coincide with required temperature and humidity of installation site and generally shall not exceed 10% moisture determined by a professional electronic pin meter (example: Protimeter Surveymaster). Subfloor pH must be between 5-9 on a pH scale.

SUBFLOOR CONSTRUCTION: Subfloors must be clean, dry, and free of any materials that might interfere with unrestricted movement. Subfloors must be soundly constructed to eliminate vertical movement. Subfloors must be flat, no more than 3/16" undulation in 10 linear feet or 1/8" in 6'. Subfloors must meet all Federal and local building codes. Patch subfloor depressions using a portland based patch, grind down high spots following acceptable installation standards. **Note: For wood substrates ensure that there is a minimum of 18" between the subfloor and the ground, the crawl space is ventilated, and there is a minimum 6mil poly sheeting installed over the entire ground surface overlapped and taped.*

APPROVED SUBSTRATES: Approved substrates include: properly prepared concrete and cement leveling compounds (minimum 3000 PSI), properly prepared gypsum (minimum 3000 PSI), and underlayment grade plywood/OSB/OFB board. For best product performance results installation on plywood over concrete is not recommended for this product.

RADIANT HEATED FLOORING: Flooring is only approved over hydronic (water) radiant heat systems. Radiant heated floors should never exceed 85 degrees Fahrenheit.

ADHESIVE RESIDUE: Never install over adhesive residue. All residue must be completely removed or properly encapsulated.

INTERIOR ONLY: This product is designed for interior climate controlled areas only.

VISUAL INSPECTION: All flooring must be inspected, in proper lighting, prior to installation. Installed material with visible defects is not covered under the flooring warranty.

ATTACHED PAD: If product comes with an attached pad, do not install an additional cushion beneath the flooring. This will void the manufacturer warranty.

PRODUCT DIRECTION: For best visual results install flooring in the same direction of direct sunlight. Use of suitable window coverings during the times of most direct sunlight is strongly recommended. Always work out of 3-5 cartons mixing products from several boxes. Always dry lay prior to final installation to insure best visual results.

CHAIR PADS AND LEG PROTECTORS: Chair pads are required under roller castors and leg protectors, a minimum of 1.5" diameter, are required under chair legs.

FLOOR PROTECTION: After installation floors must be protected from trade and other damage by a floor protection designed for this purpose.

INSTALLATER RESPONSIBILITIES

It is the floor covering installers responsibility to:

- Make sure the latest installation instructions are followed.
- Make sure the product is suitable for its intended use.
- Visually inspect all material and remove any visibly defective material. Visibly defective material installed will not be covered under warranty.
- Stop any project that does not meet installation guidelines and contact the flooring retailer it was purchased from.
- Work out of several boxes mixing product for visual appearance. Dry fit prior to installation is the recommended method.

SUITABILITY OF THE PRODUCT

This product is approved for climate controlled indoor applications only.

Approved for use in:

- Residential applications (exclusions: heavy rolling traffic such as hospital beds or electric wheelchairs)
- Multi-Family applications (exclusions: heavy rolling traffic such as hospital beds or electric wheelchairs)
- Light Commercial applications: Light commercial is defined as light traffic commercial areas such as business offices and boutique shops (exclusions: heavy rolling traffic such as hospital beds or electric wheelchairs)

Not approved for use in:

- Areas of heavy rolling loads (such as: hospital beds, electric wheelchairs)
- Heavier traffic areas, entry foyers, or any area where food is prepared or objects are rolled or dragged around
- Industrial Applications

IMPORTANT: Please read warranty for a more complete definition of acceptable use.

SITE CONDITION REQUIREMENTS (NRC)

Normal Room Conditions (NRC) must be maintained prior to, during, and after installation.

The NRC are defined as:

- Ambient air temperature between 60-85 degrees Fahrenheit
- Surface temperature between 60-85 degrees Fahrenheit
- Ambient RH (Relative Humidity) between 35%-55%
- Substrate must be dry: concrete-less than 80% RH (Relative Humidity), wood - equal to moisture content of install location (average 8%) while not exceeding 10% moisture, and pH levels between 5-9

All flooring products are required to achieve NRC prior to installation.

ACCLIMATION REQUIREMENTS

All products must acclimate to the room conditions in which they are being installed.

Flooring products (including adhesive & trim) are designed to perform in normal room conditions (NRC). Flooring products must achieve and maintain NRC 24 hours prior to, during and after installation. Temperature and Relative Humidity readings must be taken and documented, including ambient room temperature and surface temperature. Acclimate cartons laying flat, not on end or on side, stacked no more than 5 cartons high. Allow air movement between boxes. Avoid storing flooring in direct sunlight. Do not store on operational radiant in-floor heated areas. It is critical to take a surface temperature reading of the vinyl plank prior to installation, it must also be at NRC (Normal Room Conditions).

NRC (Normal Room Conditions) must be consistently maintained at:

- Room temperature between 60-85 degrees Fahrenheit
 - Surface temperature between 60-85 degrees Fahrenheit
 - Ambient RH (Relative Humidity) between 35%-55%, Moisture Content 6-10% dependent on region
 - Flooring material must be maintained between 60-85 degrees Fahrenheit
-

SUBFLOOR FLATNESS REQUIREMENTS

Subfloor must be flat, with no undulation exceeding 3/16" in a 10' radius (or 1/8" in 6'). Grind high spots down and/or fill low spots with a quality cement patching compound. Allow patch to completely dry prior to installation. Follow patch manufacturers installation guidelines.

Follow all local build regulations and OSHA procedures when grinding. Some substrates might contain harmful contaminants; such as silica sand or asbestos. It is critical that you determine prior to grinding if there are any harmful contaminants in the subfloor.

WARNING: Follow the Resilient Floor Covering Institute (RFCI) (rfci.com) recommended practices whenever grinding a substrate, existing flooring, or adhesive residue. These surfaces may contain Asbestos or other harmful contaminants.

SUBFLOOR CONSTRUCTION REQUIREMENTS

Subfloor Construction must meet all Local and Federal Building Codes:

Subfloors must be soundly constructed to eliminate vertical movement. Subfloors must be flat, not to exceed undulations exceeding 3/16" in 10' or 1/8" in 6 feet. It is the floor covering installers responsibility to ensure that subfloor conditions are suitable.

Approved Subfloors:

- Concrete, properly prepared concrete, cement patch and leveling compounds (minimum 3000 PSI). Must not exceed 80% RH (ASTM F2170), must not exceed MVER of $\leq 3\text{lbs}/1000\text{ sf}$ in 24 hours (ASTM F1869), and pH levels must be between 5-9.
- Gypsum, properly prepared gypsum (minimum 3000 PSI). Must be dry based on gypsum and adhesive manufacturer standards, maximum 80% RH (ASTM F2170).
- Wood, properly prepared wood (underlayment grade plywood, OSB & OFB). Joist spacing recommendation is glued & fastened at 16" on center (O.C.). Joists $\geq 16"$ O.C. are required to be glued and fastened at joist (ASTM D3498). Subfloor must have a minimum 18" clearance between the bottom of the joist and the ground. Ground must be covered 100% with 6-mil poly film.
- Existing floor covering that is firmly bonded to the substrate; dense not cushioned, and only one layer thick.

Non-Approved Subfloors:

- Sleeper/Screed type floor systems.
- Plywood installed directly over a concrete slab.
- Soft plywood, Luan, pressure treated, or plywood not approved as "Underlayment Grade" certified by the Plywood Association.
- Masonite or hardboard.
- Contaminated surfaces: abatement chemicals, paint, oil, mold, mildew, grease or any containments.
- Strip plank wood flooring.
- Uneven (3/16" in 10') or unstable substrates.

On Grade and Below Grade Substrates: Below grade substrates require a 6mil polyethylene film be applied to the substrate or a permanent moisture mitigation product must be applied. On grade substrates where moisture exceeds 80% RH must have a 6mil polyethylene film must be applied.

IMPORTANT: For any substrates not mentioned above check with the manufacturer before proceeding with the installation.

RADIANT HEATED FLOORS

Installation over hydronic (water) radiant heat systems is acceptable, providing the substrate never exceeds 85 degrees Fahrenheit. Prior to installing over newly constructed radiant heat systems, operate the system at maximum capacity to force any residual moisture from the cementitious topping of the radiant heat system.

A substrate temperature between 60-85 degrees Fahrenheit must be achieved prior to, maintained during, and for 48 hours after the installation. It is recommended that the radiant heat be applied in a gradual manner after installing the Luxury Vinyl flooring. Refer to the radiant heat system manufacturer's recommendations for additional guidance.

LAYOUT

- It is best to lay flooring parallel to light source (such as a window).
- Determine the center of the room by marking the center of each end wall. Snap a chalk line between these two points.
- Dry lay rows to wall, if the plank to the long wall will be less than 2" adjust the center line to make the long wall plank over 2". The goal is to have planks next to the wall to be a minimum of 2". Balance the cuts in the room.
- Stagger end joints by a minimum of 12" on a random basis.

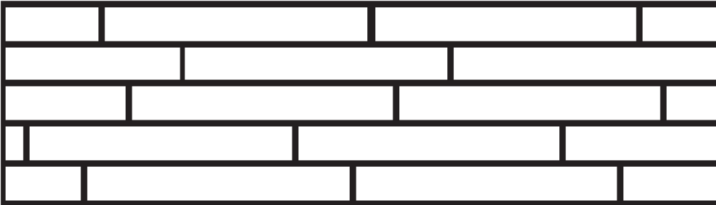

Staggered Joint Design

EXPANSION SPACE AND TRANSITIONS TRIM

Expansion Space:

- Flooring expands and contracts with normal climate changes. This product must be allowed to freely float, to expand and contract monolithically.
- At all vertical surfaces in areas up to 50' x 50', a 1/4" expansion space is required.
- Undercut door jambs and other vertical surfaces to allow flooring to freely fit underneath.
- At vertical surfaces that will not be receiving wall base or other expansion trim (such as sliding glass doors); allow a minimum 1/4 " expansion gap and caulk gap with a flexible caulking (Silicone).
- Do not fit flooring full or under compression.

Expansion Transition Trim:

- Transition trim must be used in the following:
- Areas exceeding 50' width x 50' length or 2,500 sf and with rooms which do not join symmetrically.
- Between areas of uneven heating, where one areas temperature might be maintained differently than an adjoining area.
- At doorways and sliding glass doorways, use an end cap square edge transition.
- Use transition trim in adjoining areas of irregular shape, such as but not limited to: L-Shape, U-Shape, T-Shape.
- Do not nail or staple trim so that it restricts floor movement such as nailing into floor or too tightly against floor surface.

INSTALLING ON STAIRS

- When installing on stairs, a stair nosing must be used.
- When adhering flooring to stairs use a permanent bonding adhesive (urethane adhesive or solvent-free construction adhesive).
- The attached pad must be removed.

INSTALLATION INSTRUCTIONS

STARTING YOUR INSTALLATION

Work from several open boxes of flooring and "dry lay" the floor before permanently laying the floor. This will allow you to select the varying grains & colors and to arrange them in a harmonious pattern. Remember, it is the installers' responsibility to determine the expectations of what the finished floor will look like with the end user first and then to cull out pieces that do not meet those expectations.

Inspection: Prior to installation, inspect planks in daylight for visible faults/damage. Check if subfloor/site conditions comply with the specifications described in these instructions. If you are not satisfied do not install, and contact your supplier.

Ensure the tongues on long edge joint and end joints are facing the wall. Begin installation next to an outside wall. This is usually the straightest and best reference for establishing a straight working line. Establish this line by measuring an equal distance from the wall at both ends and snapping a chalk line. The distance you measure from the wall should be the width of a plank. You may need to scribe cut the first row of planks to match the wall in order to make a straight working line if the wall is out of straight.

You may want to position a few rows before starting installation to confirm your layout decision and working line. When laying flooring, stagger end joints from row to row by at least 12". When cutting the last plank in a row to fit, you can use the cut-off end to begin the next row. If cut-off end is 12" in length or less, discard it and instead cut a new plank at a random length and use it to start the next row. Always begin each row from the same side of the room. When near a wall, you can use a pry bar to pry close the side and end joints.

Before laying: Measure the room at right angle to the direction of the planks. For best visual effect, planks in the final row should be at least 2 inches wide (half width of plank minimum). For this purpose, planks in the first row can be cut to smaller size. Shuffle planks in order to obtain a pleasant blend of shades. Lay planks preferably following the direction of the main source of light. We recommend laying on wooden floors crossways to the existing floorboard. Planks must not be nailed or screwed to the subfloor. Base boards and molding must not be fixed in a way which restricts the movement of the floor.

IMPORTANT - Do not restrict movement of the floor by placing heavy objects like kitchen islands or cabinets onto the flooring.

INSTALLATING GUIDE

1. You will need to remove the tongue on the side of the panels that face the wall. This is to ensure that the decorative surface of the floor is well under the finished trim when installed. Use a utility knife to score through the tongue several times until it easily snaps off. Start in a corner by placing the first panel with the trimmed side facing the wall. Use spacers along each wall to maintain an expansion space of 1/4" between the wall and the flooring. Adjust row so end cut is not less than 12". (F1) NOTE: This product needs room to expand and contract. At no point should you attach the floor to any surface.
2. To attach second panel, lock short end of plank by inserting tongue into groove at an angle and drop in place. Continue to end of first row. (F2)
3. Continue connecting the first row until you reach the last full panel. Fit the last panel by rotating the panel 180° with the pattern side upward, place beside row, mark and saw off excess. Attach as described above. When using a handsaw, cut on the decorative surface. If you use a jig or circular saw, cut with the decorative side down to avoid chipping. Use leftover plank from first row as starter for second row. There must be at least 12 inches between plank end joints on adjacent rows. (F3)
4. Lock short edge of plank by inserting tongue into groove at an angle and drop in place. Slide plank toward end of previously installed row until the tongue just touches the groove. Lift plank and adjacent plank(s) to engage the long-end locking system. (F4, F5)
5. **IMPORTANT** - Use hammer and tapping block to lightly tap long and short edge of plank to ensure a tight fit. **ANY GAPPING CAN COMPROMISE THE LOCKING SYSTEM.** (F6)
6. Attach a scrap piece of floor to bridge the gap between ends of planks. (F7)
7. Lightly tap end of plank with hammer and tapping block to lock ends of planks together. Remove bridge and continue towards wall until installing the final plank in the row. **BE SURE TO TAP ON EDGE OF VINYL SO AS NOT TO DAMAGE LOCKING PROFILE.** (F8)
8. To fit the last row, lay a panel on the top of the previous row. With the tongue to the wall, lay another panel upside down on the one to be measured and use it as a ruler. Don't forget to allow room for 1/4" spacers. Cut the panel and attach into position. Use hammer and pull bar to lock final piece in row. Insert spacer at end of row. Continue installation to final row. (F9)
9. Use hammer and pull bar to lock long edges of planks on final row.(F10)

10. Installing under a door jamb, undercut space under door jamb to allow plank to slide freely. Tap long edge with hammer and tapping block to lock long edge (F11), then do the same along short end of plank (F12).
11. Holes for pipes: measure the diameter of the pipe and drill a hole that is 3/4" larger. Saw off a piece as shown in the figure and lay the board in place on the floor. Then lay the sawed-off piece in place.
12. Remove spacers and install finish moldings.

COMPLETION

1. Protect all exposed edges of the flooring by installing wall molding and/or transition strips. Make sure that no plank will be secured in any way to the subfloor.
2. For wet areas such as bathrooms caulk the perimeter of the floor with a flexible silicone caulk.
3. Protect the finished flooring from exposure to direct sunlight to reduce fading and thermal expansion.

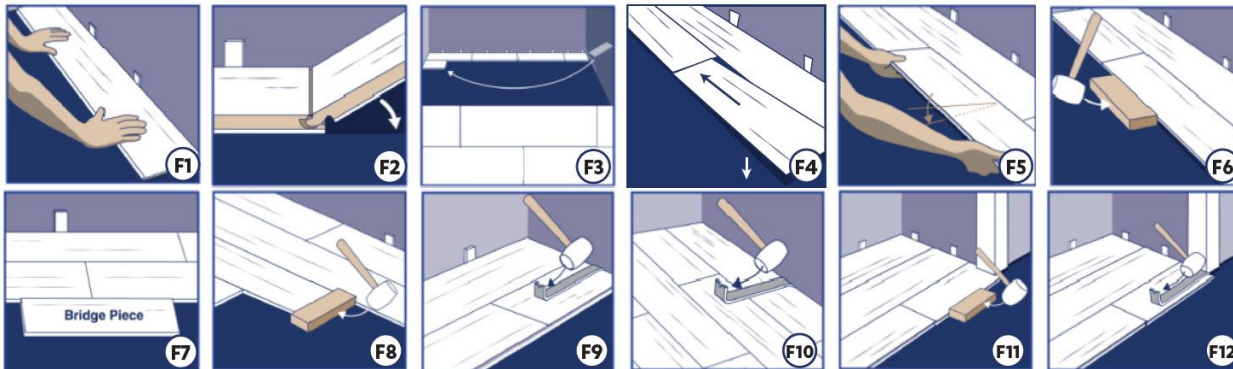

POST INSTALLATION

- If other trades are working in the installation area, protect flooring with an approved breathable floor protection material such as a builder board or reinforced 60lb Kraft paper.
- Always use chair pads under rolling caster chairs and chair leg protectors, minimum of 1.5" diameter, under furniture legs.

MAINTENANCE

Initial Maintenance

- Always use a neutral pH cleaner, such as WF Taylor Fresh Floors.
- Allow flooring to dry completely prior to foot traffic.

Daily & Weekly Maintenance

- Sweep, dust mop, or vacuum the floor as needed to remove loose dirt and grit. Do not use a vacuum with bristles or a beater bar.
- Recommend cleaning liquid spills immediately.
- Damp mop (do not flood floor) as needed.

Preventative Maintenance

- Chair pads are required under roller castor chairs.
- Furniture leg protectors, minimum 1.5" diameter, are required under all furniture legs.
- Use protective boards when sliding heavy furniture across flooring.
- Never apply rubber mats directly on top of vinyl flooring.
- Place walk off mats outside entry doors to prevent dirt and sand from entering into the installation.
- Protect flooring from direct sunlight with window and glass door coverings to prevent fading.

- Any additional floor finishes are not required and not approved. The application of any additional floor finishes will void all warranties.
-

Please Note: Floating floors are designed to expand and contract monolithically without restriction.

Special attention needs to be given to (but not limited to):

- Avoid excessive heat, such as sun rooms and area with extended direct sunlight. Excessive heat can cause uneven expansion and contraction and result in floors buckling. Window coverings can be installed to reduce excessive heat.
- Do not apply baseboard too tight to the flooring or nailing through the flooring, resulting in restricted movement.
- Do not restrict movement by installing cabinets, islands, or other heavy objects on top of the flooring. Heavy objects such as pool tables and refrigerators are acceptable as long as they do not exceed 300 PSI onto the floor.
- All subfloors must be smooth and flat, void of waxes or other contaminants that might allow the flooring to stick to the subfloor surface, restricting movement.
- Always allow proper expansion space. An expansion gap must be provided, continuously, at all vertical surfaces, allowing material to expand and contract with no restriction.
- Floors that are restricted from freely expanding and contracting are subject to buckles and gaps. Buckling and gapping due to restricted movement is not covered under warranty.

IMPORTANT: This product may come with an attached cushion, no additional cushion is required or approved. The use of additional cushion will VOID all warranties.